



### Top features

- Self-serve heated merchandisers, ideal near checkouts
- Innovative airflow technology: no hot or cold spots
- Boosts impulse sales

### Standard characteristics

- 24" wide - 3 level display
- Product temperature maintained at 149-158°F
- Ideal for chicken, wraps, snacks, soups etc.
- Upright design saves space
- Total display capacity of 8.419 ft<sup>2</sup>
- Footprint of 5.16 ft<sup>2</sup>
- Safety lighting on each level
- Shatter-resistant clear side glass for optimum safety and insulation
- Saves up to 20% on energy by air-curtain technology on each shelf
- Safe holding temperature for up to four hours
- Angled shelves provide optimum product visibility
- Illuminated replaceable signage sign at top and price strips on each shelf
- Cross-merchandising capabilities
- Front bumpers to protect from shopping carts
- Solid back as standard
- 98% recyclable (environmentally friendly)
- Plug-and-play

### Accessories

- Customer-side temperature indicator (included)
- Lower skirts covering wheels (included)
- Cross-selling top
- Cross-selling drawer
- Shelf grids

### Optional

- Doors at rear (pass through)



Signage



Cross-selling top



Rear doors



Cross-selling drawer

## Grab and Go Merchandisers



### Multi Deck 24 3 level

*Placing impulse food products near checkouts has proven to be a successful strategy in today's grab-and-go market. With the Fri-Jado Multi Deck, your customers can pick up delicious, hot, pre-packaged snacks and meal solutions practically anywhere in the store.*

*Hot air is blown from the front of the shelf and circulates within the shelf surface resulting in optimum air circulation around the hot product.*

*As the Multi Deck has limited height it can easily be installed as an aisle end or integrated in your deli department without blocking your customers' view. The large glass surface and lighting on each shelf draw extra attention to your products, boosting impulse sales.*

In-store impulse-generating merchandiser



# Multi Deck 24 3 level

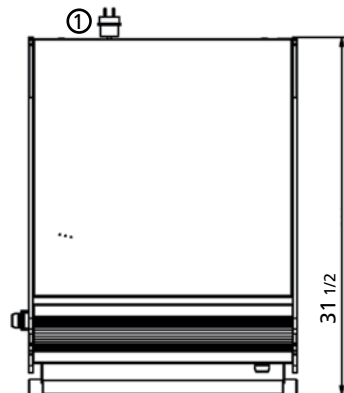
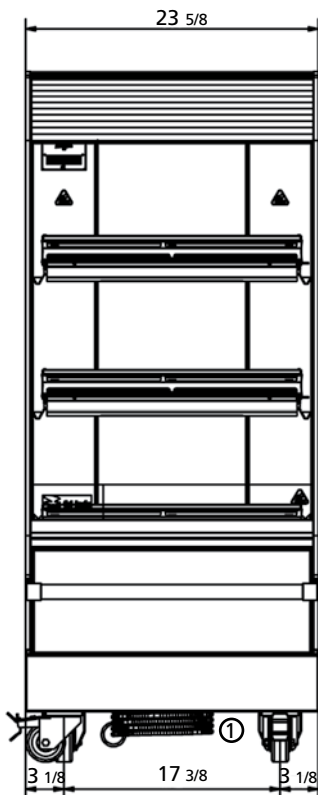
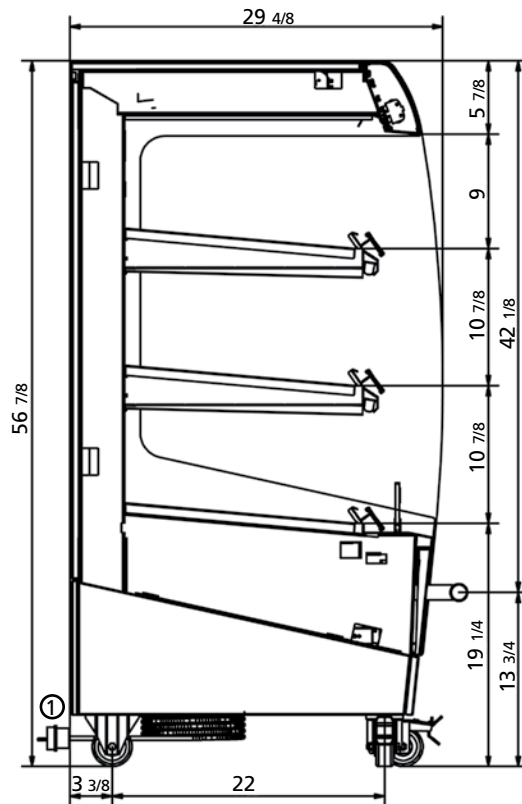

Item	Description
1	Power cable 60"

### Dimensions

Width	23 5/8"
Depth	31 1/2"
Height	56 7/8"

### Technical data

Net weight	342 lbs
Gross weight	401 lbs
Voltage	208 V
Phase	1~
Frequency	60 Hz
Power	2.4 kw
Amps	11.3 A
NEMA	6-20P





# Heated Merchandisers

## Top features

- Self-serve heated Multi Deck display unit
- Innovative airflow technology: no hot or cold spots
- Boosts impulse sales

## Standard characteristics

- 40" wide - 3 level display
- Product temperature maintained at 149-158°F
- Ideal for chicken, wraps, snacks, soups etc.
- Upright design saves space
- Total display capacity of 14.226 ft<sup>2</sup>
- Footprint of 8.6 ft<sup>2</sup>
- Safety lighting on each level
- Shatter-resistant clear side glass for optimum safety and insulation
- Saves up to 20% on energy by air-curtain technology on each shelf
- Safe holding temperature for up to four hours
- Angled shelves provide optimum product visibility
- Illuminated changeable sign at top and price strips on each shelf
- Cross-merchandising capabilities
- Front bumpers to protect from shopping carts
- Solid back as standard
- 98% recyclable (environmentally friendly)
- Plug-and-play

## Accessories

- Customer-side temperature indicator (included)
- Lower skirts covering wheels (included)
- Cross-selling top
- Cross-selling drawer

## Optional

- Doors at rear (pass through)



Signage



Cross-selling top



Rear doors



Cross-selling drawer



## Multi Deck 40 3 level

*Placing impulse food products near checkouts has proven to be a successful strategy in today's grab-and-go market. With the Fri-Jado Multi Deck, your customers can pick up delicious, hot, pre-packaged snacks and meal solutions practically anywhere in the store.*

*Hot air is blown from the front of the shelf and circulates within the shelf surface resulting in optimum air circulation around the hot product.*

*As the Multi Deck has limited height it can easily be installed as an aisle end or integrated in your deli department without blocking your customers' view. The large glass surface and lighting on each shelf draw extra attention to your products, boosting impulse sales.*

In-store impulse-generating merchandiser



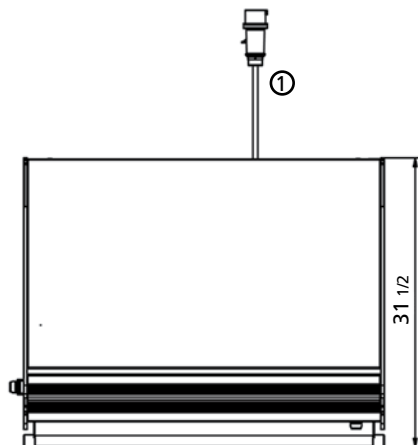
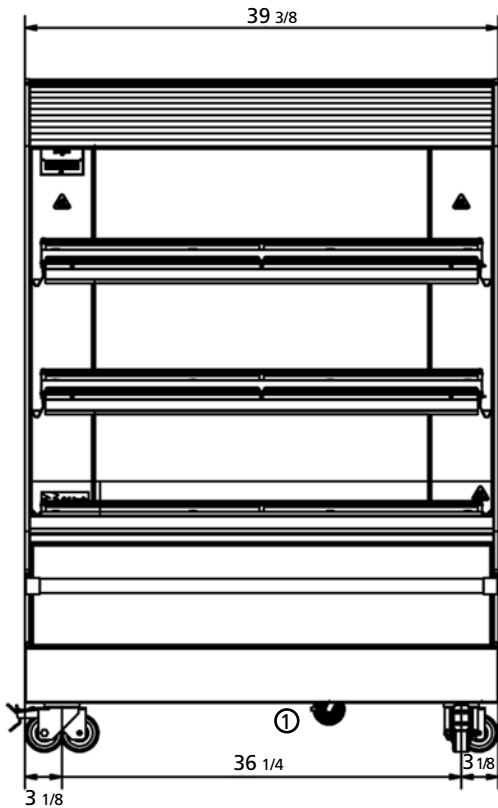
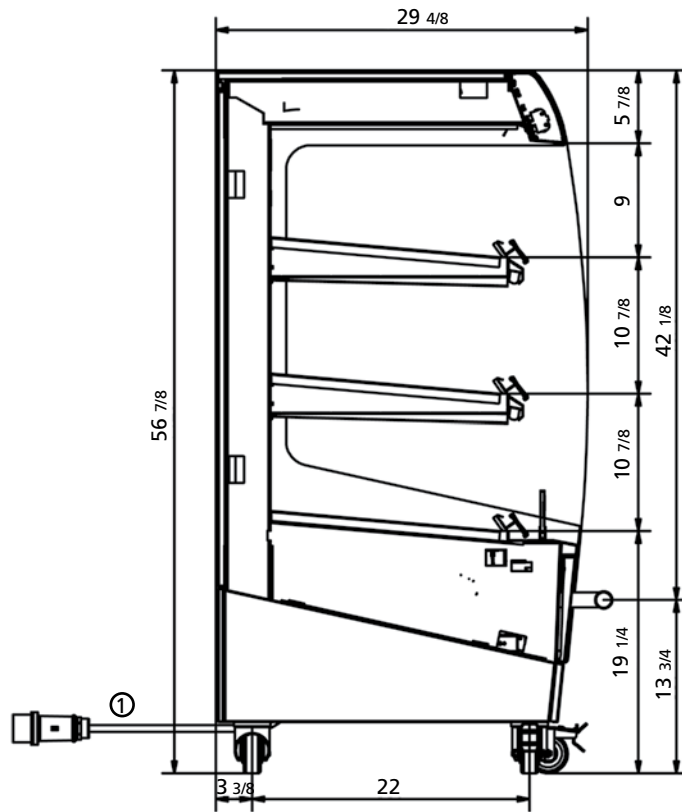

## Multi Deck 40 3 level

Item	Description
1	Power cable 60"

### Dimensions

Width	39 3/8"
Depth	31 1/2"
Height	56 7/8"

### Technical data

Net weight	441 lbs
Gross weight	518 lbs
Voltage	208 V
Phase	1~
Frequency	60 Hz
Power	3.5 kw
Amps	17 A
NEMA	6-30P





# Grab and Go Merchandisers

## Top features

- Self-serve heated Multi Deck display unit
- Innovative airflow technology: no hot or cold spots
- Boosts impulse sales

## Standard characteristics

- 48" wide - 3 level display
- Product temperature maintained at 149-158°F
- Ideal for chicken, wraps, snacks, soups etc.
- Upright design saves space
- Total display capacity of 17.129 ft<sup>2</sup>
- Footprint of 10.32 ft<sup>2</sup>
- Safety lighting on each level
- Shatter-resistant clear side glass for optimum safety and insulation
- Saves up to 20% on energy by air-curtain technology on each shelf
- Safe holding temperature for up to four hours
- Angled shelves provide optimum product visibility
- Illuminated changeable sign at top and price strips on each shelf
- Cross-merchandising capabilities
- Front bumpers to protect from shopping carts
- Solid back as standard
- 98% recyclable (environmentally friendly)
- Plug-and-play

## Accessories

- Customer-side temperature indicator (included)
- Lower skirts covering wheels (included)
- Cross-selling top
- Cross-selling drawer

## Optional

- Doors at rear (pass through)



## Multi Deck 48 3 level

*Placing impulse food products near checkouts has proven to be a successful strategy in today's grab-and-go market. With the Fri-Jado Multi Deck, your customers can pick up delicious, hot, pre-packaged snacks and meal solutions practically anywhere in the store.*

*Hot air is blown from the front of the shelf and circulates within the shelf surface resulting in optimum air circulation around the hot product.*

*As the Multi Deck has limited height it can easily be installed as an aisle end or integrated in your deli department without blocking your customers' view. The large glass surface and lighting on each shelf draw extra attention to your products, boosting impulse sales.*



Signage



Cross-selling top



Rear doors



Cross-selling drawer

# In-store impulse-generating merchandiser



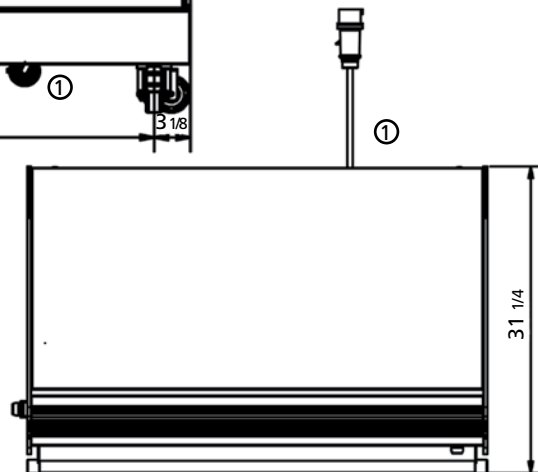
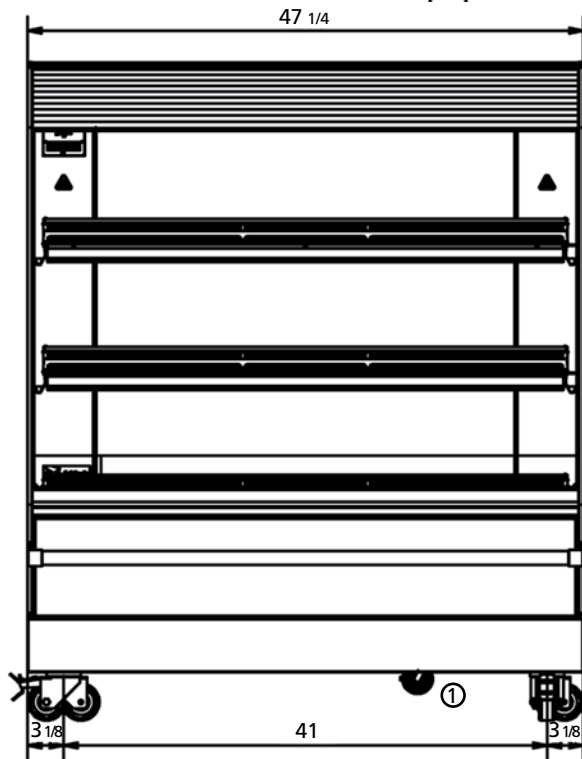
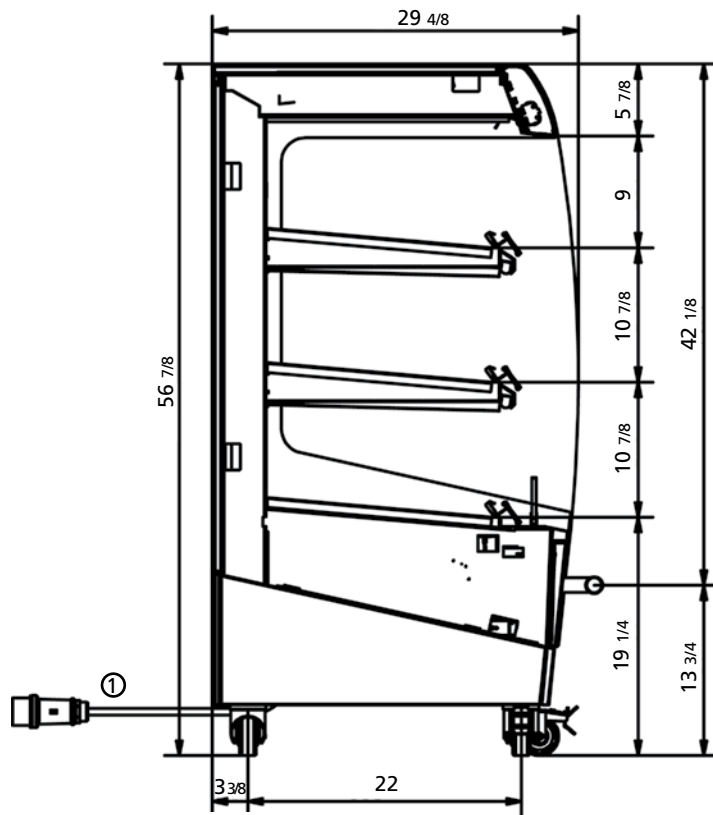

## Multi Deck 48 3 level

Item	Description
1	Power cable 60"

### Dimensions

Width	47 1/4"
Depth	31 1/2"
Height	56 7/8"

### Technical data

Net weight	474 lbs
Gross weight	558 lbs
Voltage	208 V
Phase	1~
Frequency	60 Hz
Power	4.3 kw
Amps	21 A
NEMA	6-30P



These are basic drawings.  
For more detailed technical  
information, please refer  
to the installation manual  
at [www.frijado.com](http://www.frijado.com).



Fri-Jado Inc.  
1401 Davey Road  
Suite 100  
Woodridge IL 60517  
Toll free 877-374-5236  
Fax 630-689-1424  
e-mail [us.info@frijado.com](mailto:us.info@frijado.com)  
[www.frijado.com](http://www.frijado.com)